



AIR HANDLERS

**CBX32M
ELITE SERIES®**

R-410A Ready - Multi-Position

PRODUCT SPECIFICATIONS

Bulletin No. 210351
February 2014
Supersedes October 2013



**Nominal Capacity - 1.5 to 5 Tons
Optional Electric Heat - 2.5 to 30 kW**

MODEL NUMBER IDENTIFICATION

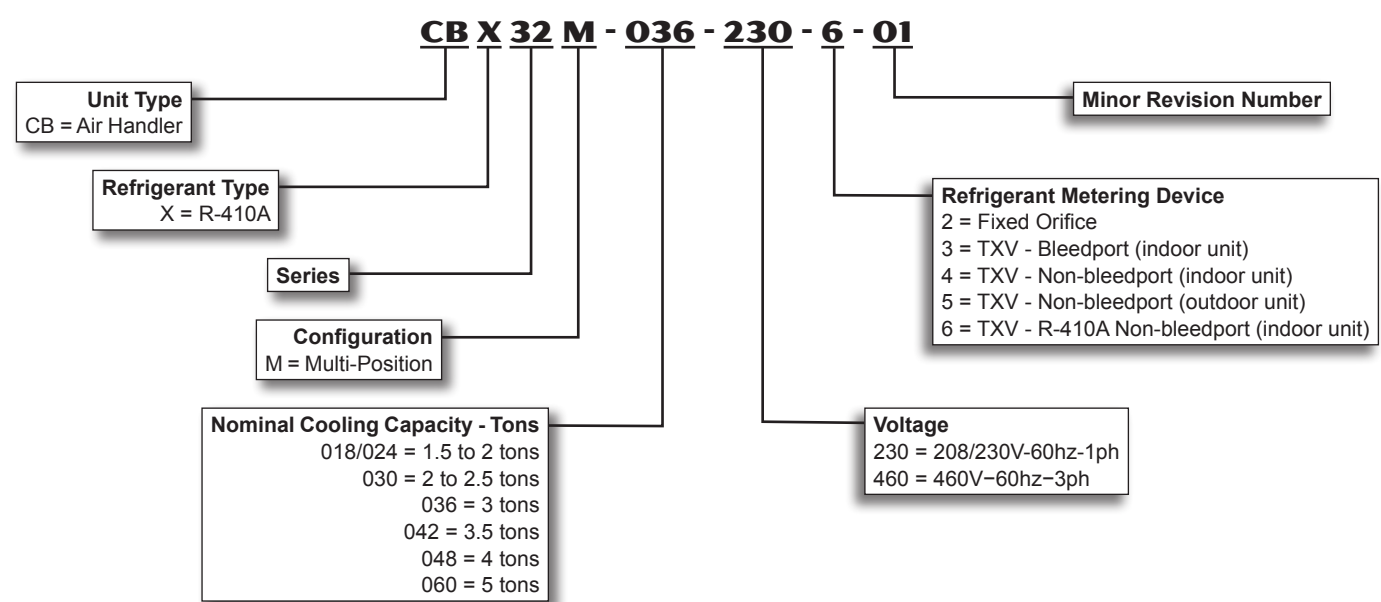

FEATURES

CONTENTS

Blower Data	6
Dimensions	16
Electrical Data.....	5
Electric Heat Data.....	8
Features.....	2
Installation Clearances With Electric Heat	5
Model Number Identification	1
Optional Accessories	5
Specifications.....	5

WARRANTY

All covered components - Limited five years in residential applications, one year in non-residential applications.

Refer to Lennox Limited Warranty Certificate included with each unit for additional details.

APPROVALS

Tested with matching air conditioners and heat pump units in the Lennox Research Laboratory environmental test room in accordance with AHRI Standard 210/240.

Optional electric heaters are rated in accordance with US Department of Energy (DOE) test procedures and Federal Trade Commission (FTC) labeling regulations.

Blower performance data according to unit tests conducted in Lennox air test chamber.

Air handlers are UL Listed to US and Canadian safety standards and components within are bonded for grounding to meet safety standards for servicing required by CEC and NEC.

Air handler units are approved for installation in manufactured housing and mobile homes.

ISO 9001 Registered Manufacturing Quality System.

APPLICATIONS

1.5 to 5 ton nominal sizes.

Multi-position (upflow, downflow or horizontal) applications.

Applicable to expansion valve systems in R-410A cooling applications and check and expansion valve systems in R-410A heat pump applications.

See bulletins in section Air Conditioners for cooling capacities.

See bulletins in section Heat Pump Outdoor Units for cooling and heating capacities.

Optional field installed electric heaters available in several sizes for additive heating capacity.



REFRIGERANT SYSTEM

- 1 Copper Tube/Enhanced Fin Indoor Coil**
Lennox designed and fabricated twin coils.
Assembled in "A" configuration.
Provides extra large surface and contact area, excellent heat transfer and low air resistance for maximum efficiency.
Precise circuiting for uniform refrigerant distribution.
Precisely spaced ripple-edged aluminum fins fitted to durable seamless copper tubes.
Fins are strengthened to resist bending and are equipped with collars that grip tubing for maximum contact area.
Lanced fins provide maximum exposure of fin surface to air stream.
Long life copper tubing is easy to service.
Rifled tubing provides superior heat transfer.
Flared shoulder tubing joints and silver soldering provide tight, leakproof joints.
Coil thoroughly factory tested under high pressure to insure leakproof construction.

FEATURES

REFRIGERANT SYSTEM (continued)

2 Refrigerant Line Connections

Suction (vapor) and liquid lines have sweat connections that extended outside of the cabinet for ease of connection.

See dimension drawings for locations.

3 Check and Expansion Valve Furnished

For use with R-410A systems.

Wide range valve with Chatleff style fitting.

Factory installed on all models, internal to cabinet.



CABINET

4 Constructed of heavy-gauge galvanized steel.

Completely insulated with thick fiberglass insulation.

Pre-painted steel cabinets have mildly textured enamel finish with primer coat on unpainted side of all panels.

Units are shipped in one piece but may be disassembled into two separate sections for ease of installation in tight applications. See dimension drawings.

Thick rubber gasket between sections of the two piece cabinets provides an air tight seal.

No external screw heads on sides of cabinet for tight installations without damage to walls or woodwork.

Removable panels provide complete service access.

Electrical inlets provided in sides and top of cabinet. See dimension drawings for locations.

Low Leakage Cabinet

All models have less than 2% air leakage and meet ANSI/ASHRAE Standard 193-2010 "Method of Test for Determining the Air Tightness of HVAC Equipment".

Multi-Position Capability

Shipped for upflow and horizontal right-hand discharge.

Quickly converted to downflow or left-hand, horizontal air discharge.

Optional Kit required for conversion to downflow.

Drain Pans

Drain pans designed for upflow, downflow or horizontal applications.

Deep, corrosion resistant plastic drain pans have dual pipe drains.

See dimension drawings.

Optional Accessories

Downflow Combustible Flooring Base

Base is required for models with electric heat installed in downflow position on combustible floors.

Horizontal Support Frame Kit

Provides support of unit in horizontal applications.

Consists of (2) 1 x 1-1/2 x 32-5/8 in. and (2) 1 x 3 x 53-7/8 in. painted heavy gauge cold rolled steel support channels with assembly and suspending holes.

Bolts and nuts furnished for field assembly.

Suspending rods must be field provided.

Side Return Unit Stand (Upflow Only)

Raises unit 16 in. above floor for side return air duct connection.

Eliminates need for wooden platform construction.

All aluminum construction.

Two adjustable frames fit -018/024 thru -060 models.

Wall Hanging Bracket Kit (Upflow Only)

Allows unit to be hung on wall at any height.

Consists of heavy-gauge steel support brackets (one for air handler, one for wall mount).

Screws furnished for fastening one bracket to unit.

Bolts for fastening one bracket to wall are field provided.

BLOWER

5 Lennox designed and built direct-drive blower.

Statically and dynamically balanced before installation in unit.

Resiliently mounted multi-speed leadless motor with plug-in connections.

Choice of blower speeds. See blower performance tables.

Speed changes easily accomplished by a simple wiring change.

Blower slides out of cabinet for servicing.

CONTROLS

6 Transformer and Blower Cooling Relay

24 volt transformer with in-line fuse and blower cooling relay furnished as standard.

Factory installed in the unit control box.

Terminal strip furnished.

Optional Accessories

Thermostat

See Thermostat bulletins in Controls section and Lennox Price Book for a complete list of thermostats.

FEATURES

OPTIONAL ELECTRIC HEAT

7 Field install internal to unit cabinet.

Available in several voltages and kW sizes.

See Electric Heat tables.

Helix wound nichrome heating elements exposed directly in air stream resulting in instant heat transfer, low element temperatures and long service life.

Each element equipped with accurately located limit control with fixed temperature off setting and automatic reset.

Supplemental thermal cutoff limit control, provides positive protection in case of excessive temperatures.

Thermal sequencer relay brings elements on and off line, in sequence and equal increments, with time delay between each.

Initiates and terminates blower operation.

Heating control relay(s) furnished as standard.

Control box and access cover constructed of heavy gauge galvanized steel.

Factory assembled with controls installed and wired.

Electric heat low voltage controls plug-in to air handler.

Circuit Breaker Models

The following heaters are equipped with circuit breakers for overload and short circuit protection:

ECB29-4CB, -5CB, -6CB, -8CB, -9CB, -10CB, -12.5CB, -15CB, -20CB, -25CB and -30CB (208/240V-1ph)

ECB29-15CB, -20CB and -25CB (208/240V-3ph)

Factory wired and mounted on electric heat unit.

Current sensitive and temperature actuated.

Manual reset.

Circuit breakers qualify as disconnect means at unit in many areas, eliminate the need for field provided disconnect.

Consult local electrical code in your area.

NOTE - 460V-3 phase air handlers can be used in 575V applications.

575V electric heaters are shipped with a 575V to 460V step-down transformer.

EvenHeater™ Models

Electric heat is staged to provide supplemental heat to meet desired comfort levels.

EHC control board stages the heat on and off based on the demand of the provided (field installed) discharge air sensor.

Temperature set point (85, 100, 115 or 130°F) is selected by use of a jumper pin on the EHC control board.

ECB29EH-9CB, -12.5CB, -15CB and -20CB heaters are equipped with circuit breakers for overload and short circuit protection.

Factory provided and field mounted in electric heat unit.

Current sensitive and temperature actuated.

Manual reset.

Circuit breakers qualify as disconnect means at unit in many areas, eliminate the need for field provided disconnect.

Consult local electrical code in your area.

Optional Accessories

Circuit Breaker Cover Kit

Flexible plastic cover protects circuit breaker.

Recommended in areas with high humidity or unconditioned areas to prevent nuisance tripping.

Single-Point Power Source Control Box

Control Box may be used with optional electric heat when single power supply is connected to multi-circuit electric heat.

Field installs external to the unit cabinet on either side or top.

Constructed of heavy gauge steel, baked enamel finish, prepunched mounting holes, electrical inlet knockouts, and terminal strip.

Removable cover provides easy access.

Dimensions (H x W x D) - 7 x 7 x 4 in.

INDOOR AIR QUALITY

8 Air Filter

Tool-less access to filter area for quick and easy servicing.

Disposable frame type filter furnished and factory installed in rails in cabinet.

See Specifications tables for sizes.

SPECIFICATIONS

General Data		Model Number	CBX32M -018/024	CBX32M -030	CBX32M -036	CBX32M -042	CBX32M -048	CBX32M -060
	Nominal Tonnage		1.5 - 2	2.5	3	3.5	4	5
	Refrigerant		R-410A	R-410A	R-410A	R-410A	R-410A	R-410A
Connections in.	Suction (vapor) line - sweat		5/8	3/4	3/4	7/8	7/8	7/8
	Liquid line - sweat		3/8	3/8	3/8	3/8	3/8	3/8
	Condensate drain - fpt		(2) 3/4	(2) 3/4	(2) 3/4	(2) 3/4	(2) 3/4	(2) 3/4
Evaporator Coil	Net face area - ft. ²		3.56	4.44	5.0	5.0	7.22	7.22
	Tube outside diameter - in.		3/8	3/8	3/8	3/8	3/8	3/8
	Number of rows		3	3	3	3	3	3
	Fins per inch		12	12	12	12	12	12
Blower Data	Wheel nom. diameter x width - in.		10 x 7	10 x 8	11 x 8	11 x 8	11-1/2 x 9	12 x 9
	Blower motor output - hp		1/5	1/3	1/3	1/3	1/3	1/2
Filters	¹ Number		1	1	1	1	1	1
	Size - in.		15 x 20 x 1	20 x 20 x 1	20 x 20 x 1	20 x 20 x 1	20 x 24 x 1	20 x 24 x 1
Shipping Data	1 Package - lbs.		136	157	177	181	206	206

ELECTRICAL DATA

	Voltage - 1 phase	208/230V	208/230V	208/230V	208/230V	208/230V	208/230V
	Voltage - 3 phase	---	---	³ 460V	---	³ 460V	³ 460V
	² Maximum overcurrent protection (unit only) all voltages	15	15	15	15	15	15
	Minimum circuit ampacity (unit only) - 208/230V 460V	2	2	2	3	3	5
		---	---	2	---	2	3

OPTIONAL ACCESSORIES - ORDER SEPARATELY

Circuit Breaker Cover Kit	82W01	82W01	82W01	82W01	82W01	82W01
Downflow Combustible Flooring Base	34J72	44K15	44K15	44K15	44K15	44K15
Downflow Conversion Kit	83M57	83M57	83M57	83M57	83M57	83M57
Horizontal Support Frame Kit	56J18	56J18	56J18	56J18	56J18	56J18
Side Return Unit Stand (Upflow)	45K31	45K32	45K32	45K32	45K32	45K32
Single-Point Power Source Control Box	21H39	21H39	21H39	21H39	21H39	21H39
Wall Hanging Bracket Kit (Upflow)	45K30	45K30	45K30	45K30	45K30	45K30

¹ Disposable frame type filter.

² HACR type circuit breaker or fuse.

³ Blower motor is 460V - 1 phase. Optional electric heat is 460V - 3 phase.

REPLACEMENT CIRCUIT BREAKERS

Voltage	25 amp	30 amp	35 amp	40 amp	45 amp	50 amp	60 amp
208/240V - 1 Phase 2 pole breaker	41K13	17K70	72K07	49K14	17K71	41K12	17K72
208/240V - 3 Phase 3 pole breaker	---	64W47	---	41K16	18M86	41K15	41K17

INSTALLATION CLEARANCES WITH ELECTRIC HEAT

Cabinet	0 inch (0 mm)
To Plenum	1 inch (25 mm)
To Outlet Duct within 3 feet (914 mm)	1 inch (25 mm)
Floor	See Note #1
Service / Maintenance	See Note #2

¹ Units installed on combustible floors in the downflow position with electric heat require optional downflow combustible flooring base.

² Front service access - 24 inches (610 mm) minimum.

NOTE - If cabinet depth is more than 24 inches (610 mm), allow a minimum of the cabinet depth plus 2 inches (51 mm).

BLOWER DATA

CBX32M-018/024 BLOWER PERFORMANCE (208/230V)

External Static Pressure in. w.g.	Air Volume & Motor Watts at Specific Blower Taps					
	High		Medium		Low	
	cfm	Watts	cfm	Watts	cfm	Watts
0	1030	365	895	300	700	245
0.05	1015	360	890	295	695	245
0.10	1000	355	875	290	690	240
0.15	980	345	860	285	680	235
0.20	960	340	845	280	665	230
0.25	935	335	825	275	650	220
0.30	910	325	800	265	635	215
0.40	850	310	745	250	590	205
0.50	780	295	685	235	535	190
0.60	705	280	605	220	470	175
0.70	615	265	520	200	395	165
0.75	565	255	475	195	350	155

NOTE - All air data is measured external to unit with air filter in place with bottom return air.
Electric heaters have no appreciable air resistance.

CBX32M-030 BLOWER PERFORMANCE (208/230V)

External Static Pressure in. w.g.	Air Volume & Motor Watts at Specific Blower Taps					
	High		Medium		Low	
	cfm	Watts	cfm	Watts	cfm	Watts
0	1290	385	1175	335	1045	315
0.05	1295	380	1190	330	1075	310
0.10	1290	375	1190	325	1085	300
0.15	1265	370	1175	320	1085	295
0.20	1230	360	1145	310	1065	285
0.25	1180	350	1105	295	1030	270
0.30	1115	335	1045	280	980	255
0.40	945	305	890	250	830	220
0.50	720	275	675	215	615	190
0.60	440	240	405	185	335	160

NOTE - All air data is measured external to unit with air filter in place with bottom return air.
Electric heaters have no appreciable air resistance.

CBX32M-036 BLOWER PERFORMANCE (208/230V)

External Static Pressure in. w.g.	Air Volume & Motor Watts at Specific Blower Taps					
	High		Medium		Low	
	cfm	Watts	cfm	Watts	cfm	Watts
0	1525	505	1120	390	915	335
0.05	1520	495	1150	385	965	330
0.10	1510	480	1170	380	1005	325
0.15	1495	470	1180	375	1035	320
0.20	1475	455	1190	370	1055	320
0.25	1450	440	1185	360	1060	310
0.30	1415	430	1175	350	1050	300
0.40	1335	400	1135	325	1005	290
0.50	1230	375	1060	300	915	255
0.60	1100	345	960	280	775	230
0.70	950	320	830	255	590	205
0.75	870	305	750	245	485	195

NOTE - All air data is measured external to unit with air filter in place with bottom return air.
Electric heaters have no appreciable air resistance.

CBX32M-036 BLOWER PERFORMANCE (460V)

External Static Pressure in. w.g.	Air Volume & Motor Watts at Specific Blower Taps			
	High		Low	
	cfm	Watts	cfm	Watts
0	1525	505	1120	390
0.05	1520	495	1150	385
0.10	1510	480	1170	380
0.15	1495	470	1180	375
0.20	1475	455	1190	370
0.25	1450	440	1185	360
0.30	1415	430	1175	350
0.40	1335	400	1135	325
0.50	1230	375	1060	300
0.60	1100	345	960	280
0.70	950	320	830	255
0.75	870	305	750	245

NOTE - All air data is measured external to unit with air filter in place with bottom return air.
Electric heaters have no appreciable air resistance.

CBX32M-042 BLOWER PERFORMANCE (208/230V)

External Static Pressure in. w.g.	Air Volume & Motor Watts at Specific Blower Taps					
	High		Medium		Low	
	cfm	Watts	cfm	Watts	cfm	Watts
0	1825	565	1600	455	1325	370
0.05	1790	555	1585	455	1335	370
0.10	1750	540	1565	450	1335	370
0.15	1710	530	1540	440	1330	365
0.20	1660	520	1505	435	1320	360
0.25	1610	505	1470	425	1300	355
0.30	1555	495	1425	415	1270	350
0.40	1430	465	1320	390	1195	330
0.50	1290	440	1195	365	1090	310
0.60	1135	415	1050	335	955	285
0.70	965	385	875	310	795	260
0.75	875	370	780	295	700	250

NOTE - All air data is measured external to unit with air filter in place with bottom return air.
Electric heaters have no appreciable air resistance.

BLOWER DATA

CBX32M-048 BLOWER PERFORMANCE (208/230V)

External Static Pressure in. w.g.	Air Volume & Motor Watts at Specific Blower Taps					
	High		Medium		Low	
	cfm	Watts	cfm	Watts	cfm	Watts
0	1910	590	1785	520	1475	430
0.05	1895	585	1770	515	1480	430
0.10	1870	580	1750	510	1475	425
0.15	1840	570	1720	500	1465	420
0.20	1800	565	1685	490	1445	410
0.25	1755	550	1645	480	1415	405
0.30	1700	540	1600	465	1380	395
0.40	1580	515	1485	440	1290	370
0.50	1425	485	1350	410	1170	345
0.60	1250	450	1190	380	1020	320
0.70	1045	415	1000	350	840	295
0.75	930	400	900	335	740	280

NOTE - All air data is measured external to unit with air filter in place with bottom return air.

Electric heaters have no appreciable air resistance.

CBX32M-048 BLOWER PERFORMANCE (460V)

External Static Pressure in. w.g.	Air Volume & Motor Watts at Specific Blower Taps			
	High		Low	
	cfm	Watts	cfm	Watts
0	1870	610	1775	530
0.05	1875	610	1775	530
0.10	1870	590	1765	515
0.15	1850	585	1750	510
0.20	1825	575	1720	500
0.25	1790	560	1685	490
0.30	1745	545	1645	480
0.40	1625	505	1530	450
0.50	1465	470	1380	420
0.60	1270	425	1195	385
0.70	1030	385	975	350
0.75	755	340	720	320

NOTE - All air data is measured external to unit with air filter in place with bottom return air.

Electric heaters have no appreciable air resistance.

CBX32M-060 BLOWER PERFORMANCE (208/230V)

External Static Pressure in. w.g.	Air Volume & Motor Watts at Specific Blower Taps					
	High		Medium		Low	
	cfm	Watts	cfm	Watts	cfm	Watts
0	2115	780	2025	670	1775	585
0.05	2100	770	2010	665	1775	590
0.10	2085	765	1995	655	1770	580
0.15	2060	750	1975	645	1760	570
0.20	2030	740	1950	635	1745	560
0.25	2000	730	1915	625	1725	550
0.30	1960	715	1880	610	1695	535
0.40	1870	685	1795	580	1630	505
0.50	1755	655	1690	545	1540	475
0.60	1620	625	1560	515	1425	440
0.70	1465	590	1415	480	1295	410
0.80	1290	560	1250	445	1140	375
0.85	1195	545	1160	425	1050	360

NOTE - All air data is measured external to unit with air filter in place with bottom return air.

Electric heaters have no appreciable air resistance.

CBX32M-060 BLOWER PERFORMANCE (460V)

External Static Pressure in. w.g.	Air Volume & Motor Watts at Specific Blower Taps			
	High		Low	
	cfm	Watts	cfm	Watts
0	2140	795	1965	710
0.05	2110	780	1950	700
0.10	2080	765	1930	685
0.15	2045	755	1910	675
0.20	2005	740	1880	660
0.25	1965	725	1850	645
0.30	1920	710	1815	630
0.40	1820	680	1735	600
0.50	1710	650	1635	570
0.60	1585	615	1520	540
0.70	1450	585	1390	505
0.80	1305	550	1245	475
0.85	1225	535	1165	460

NOTE - All air data is measured external to unit with air filter in place with bottom return air.

Electric heaters have no appreciable air resistance.

ELECTRIC HEAT DATA - CBX32M-018/024

Model Number	No. of Stages	Input			² Blower Motor Full Load Amps	³ Minimum Circuit Ampacity	⁵ Maximum Overcurrent Protection	
		Volts	kW	¹ Btuh				
SINGLE PHASE								
2.5 kW 4 lbs.	ECB29-2.5 (28K30)	1	208	1.9	6,400	1.5	13	15
			220	2.1	7,200	1.5	15	15
			230	2.3	7,800	1.5	15	15
			240	2.5	8,500	1.5	15	15
4 kW 4 lbs.	ECB29-4 (55W87) Terminal Block ECB29-4CB (55W88) 30A Circuit breaker	1	208	3.0	10,250	1.5	20	20
			220	3.4	11,450	1.5	23	25
			230	3.7	12,550	1.5	23	25
			240	4.0	13,650	1.5	23	25
5 kW 4 lbs.	ECB29-5 (28K31) Terminal Block ECB29-5CB (28K32) 30A Circuit breaker	1	208	3.8	12,800	1.5	24	⁴ 25
			220	4.2	14,300	1.5	28	30
			230	4.6	15,700	1.5	28	30
			240	5.0	17,100	1.5	28	30
6 kW 4 lbs.	ECB29-6 (47L22) Terminal Block ECB29-6CB (47L23) 35A Circuit breaker	1	208	4.5	15,400	1.5	29	⁴ 30
			220	5.0	17,100	1.5	33	35
			230	5.5	18,800	1.5	33	35
			240	6.0	20,500	1.5	33	35
8 kW 5 lbs.	ECB29-8 (28K33) Terminal Block ECB29-8CB (28K34) 45A Circuit breaker	1	208	6.0	20,500	1.5	38	⁴ 40
			220	6.7	22,900	1.5	44	45
			230	7.3	25,100	1.5	44	45
			240	8.0	27,300	1.5	44	45
9 kW 5 lbs.	ECB29-9CB (10L11) 60A Circuit breaker ECB29EH-9CB (91K67) 60A Circuit breaker	2	208	6.8	23,100	1.5	42	⁴ 45
			220	7.6	25,800	1.5	49	⁴ 50
			230	8.3	28,200	1.5	49	⁴ 50
			240	9.0	30,700	1.5	49	⁴ 50
10 kW 6 lbs.	ECB29-10 (28K35) Terminal Block ECB29-10CB (28K36) 60A Circuit breaker	2	208	7.5	25,600	1.5	47	⁴ 50
			220	8.4	28,700	1.5	54	60
			230	9.2	31,400	1.5	54	60
			240	10.0	34,100	1.5	54	60

NOTE - Circuit 1 Minimum Circuit Ampacity includes the Blower Motor Full Load Amps.

¹ Electric heater capacity only - does not include additional blower motor heat capacity.

² Amps shown are for blower motor only.

³ Refer to National or Canadian Electrical Code manual to determine wire, fuse and disconnect size requirements. Use wires suitable for at least 167°F (75°C).

⁴ Bold text indicates that the circuit breaker on CB" circuit breaker models must be replaced with size noted. See Table on Page 5.

⁵ HACR type circuit breaker or fuse.

ELECTRIC HEAT DATA - CBX32M-030

Model Number	No. of Stages	Input			² Blower Motor Full Load Amps	³ Minimum Circuit Ampacity		⁵ Maximum Overcurrent Protection		Single Point Power Source		
		Volts	kW	¹ Btuh		Ckt 1	Ckt 2	Ckt 1	Ckt 2	³ Minimum Circuit Ampacity	⁵ Maximum Overcurrent Protection	
SINGLE PHASE												
4 kW 4 lbs.	ECB29-4 (55W87) Terminal Block ECB29-4CB (55W88) 30A Circuit breaker	1	208	3.0	10,250	1.73	20	---	⁴ 20	---	---	---
			220	3.4	11,450	1.73	23	---	⁴ 25	---	---	---
			230	3.7	12,550	1.73	23	---	⁴ 25	---	---	---
			240	4.0	13,650	1.73	23	---	⁴ 25	---	---	---
5 kW 4 lbs.	ECB29-5 (28K31) Terminal Block ECB29-5CB (28K32) 30A Circuit breaker	1	208	3.8	12,800	1.73	25	---	⁴ 25	---	---	---
			220	4.2	14,300	1.73	28	---	30	---	---	---
			230	4.6	15,700	1.73	28	---	30	---	---	---
			240	5.0	17,100	1.73	28	---	30	---	---	---
6 kW 4 lbs.	ECB29-6 (47L22) Terminal Block ECB29-6CB (47L23) 35A Circuit breaker	1	208	4.5	15,400	1.73	30	---	⁴ 30	---	---	---
			220	5.0	17,100	1.73	33	---	35	---	---	---
			230	5.5	18,800	1.73	33	---	35	---	---	---
			240	6.0	20,500	1.73	33	---	35	---	---	---
8 kW 5 lbs.	ECB29-8 (28K33) Terminal Block ECB29-8CB (28K34) 45A Circuit breaker	1	208	6.0	20,500	1.73	38	---	⁴ 40	---	---	---
			220	6.7	22,900	1.73	44	---	45	---	---	---
			230	7.3	25,100	1.73	44	---	45	---	---	---
			240	8.0	27,300	1.73	44	---	45	---	---	---
9 kW 5 lbs.	ECB29-9CB (10L11) 60A Circuit breaker ECB29EH-9CB (91K67) 60A Circuit breaker	2	208	6.8	23,100	1.73	43	---	⁴ 45	---	---	---
			220	7.6	25,800	1.73	49	---	⁴ 50	---	---	---
			230	8.3	28,200	1.73	49	---	⁴ 50	---	---	---
			240	9.0	30,700	1.73	49	---	⁴ 50	---	---	---
10 kW 6 lbs.	ECB29-10 (28K35) Terminal Block ECB29-10CB (28K36) 60A Circuit breaker	2	208	7.5	25,600	1.73	47	---	⁴ 50	---	---	---
			220	8.4	28,700	1.73	54	---	60	---	---	---
			230	9.2	31,400	1.73	54	---	60	---	---	---
			240	10.0	34,100	1.73	54	---	60	---	---	---
12.5 kW 10 lbs.	ECB29-12.5CB (28K37) (1) 25A and (1) 50A Circuit breaker ECB29EH-12.5CB (91K68) (1) 25A and (1) 50A Circuit breaker	2	208	9.4	32,000	1.73	21	31	25	⁴ 45	60	60
			220	10.5	35,800	1.73	24	35	25	50	61	70
			230	11.5	39,200	1.73	24	35	25	50	61	70
			240	12.5	42,600	1.73	24	35	25	50	67	70
15 kW 12 lbs.	ECB29-15CB (28K38) (1) 30A and (1) 60A Circuit breaker ECB29EH-15CB (91K69) (1) 30A and (1) 60A Circuit breaker	2	208	11.3	38,400	1.73	24	37	⁴ 25	⁴ 50	71	80
			220	12.6	43,000	1.73	28	42	30	60	72	80
			230	13.8	47,000	1.73	28	42	30	60	72	80
			240	15.0	51,200	1.73	28	42	30	60	80	80

NOTE - Circuit 1 Minimum Circuit Ampacity includes the Blower Motor Full Load Amps.

¹ Electric heater capacity only - does not include additional blower motor heat capacity.

² Amps shown are for blower motor only.

³ Refer to National or Canadian Electrical Code manual to determine wire, fuse and disconnect size requirements. Use wires suitable for at least 167°F (75°C).

⁴ Bold text indicates that the circuit breaker on CB* circuit breaker models must be replaced with size noted. See Table on Page 5.

⁵ HACR type circuit breaker or fuse.

ELECTRIC HEAT DATA - CBX32M-036

Model Number	No. of Stages	Input			² Blower Motor Full Load Amps	³ Minimum Circuit Ampacity		⁵ Maximum Overcurrent Protection		Single Point Power Source		
		Volts	kW	¹ Btuh		Ckt 1	Ckt 2	Ckt 1	Ckt 2	³ Minimum Circuit Ampacity	⁵ Maximum Overcurrent Protection	
SINGLE PHASE												
4 kW 4 lbs.	ECB29-4 (55W87) Terminal Block ECB29-4CB (55W88) 30A Circuit breaker	1	208	3.0	10,250	1.72	20	---	⁴ 20	---	---	---
			220	3.4	11,450	1.72	23	---	⁴ 25	---	---	---
			230	3.7	12,550	1.72	23	---	⁴ 25	---	---	---
			240	4.0	13,650	1.72	23	---	⁴ 25	---	---	---
5 kW 4 lbs.	ECB29-5 (28K31) Terminal Block ECB29-5CB (28K32) 30A Circuit breaker	1	208	3.8	12,800	1.72	25	---	⁴ 25	---	---	---
			220	4.2	14,300	1.72	28	---	30	---	---	---
			230	4.6	15,700	1.72	28	---	30	---	---	---
			240	5.0	17,100	1.72	28	---	30	---	---	---
6 kW 4 lbs.	ECB29-6 (47L22) Terminal Block ECB29-6CB (47L23) 35A Circuit breaker	1	208	4.5	15,400	1.72	30	---	⁴ 30	---	---	---
			220	5.0	17,100	1.72	33	---	35	---	---	---
			230	5.5	18,800	1.72	33	---	35	---	---	---
			240	6.0	20,500	1.72	33	---	35	---	---	---
8 kW 5 lbs.	ECB29-8 (28K33) Terminal Block ECB29-8CB (28K34) 45A Circuit breaker	1	208	6.0	20,500	1.72	38	---	⁴ 40	---	---	---
			220	6.7	22,900	1.72	44	---	45	---	---	---
			230	7.3	25,100	1.72	44	---	45	---	---	---
			240	8.0	27,300	1.72	44	---	45	---	---	---
9 kW 5 lbs.	ECB29-9CB (10L11) 60A Circuit breaker ECB29EH-9CB (91K67) 60A Circuit breaker	2	208	6.8	23,100	1.72	43	---	⁴ 45	---	---	---
			220	7.6	25,800	1.72	49	---	⁴ 50	---	---	---
			230	8.3	28,200	1.72	49	---	⁴ 50	---	---	---
			240	9.0	30,700	1.7	49	---	⁴ 50	---	---	---
10 kW 6 lbs.	ECB29-10 (28K35) Terminal Block ECB29-10CB (28K36) 60A Circuit breaker	2	208	7.5	25,600	1.72	47	---	⁴ 50	---	---	---
			220	8.4	28,700	1.72	54	---	60	---	---	---
			230	9.2	31,400	1.72	54	---	60	---	---	---
			240	10.0	34,100	1.72	54	---	60	---	---	---
12.5 kW 10 lbs.	ECB29-12.5CB (28K37) (1) 25A & (1) 50A Circuit breaker ECB29EH-12.5CB (91K68) (1) 25A & (1) 50A Circuit breaker	2	208	9.4	32,000	1.72	21	31	25	⁴ 45	60	60
			220	10.5	35,800	1.72	24	35	25	50	61	70
			230	11.5	39,200	1.72	24	35	25	50	61	70
			240	12.5	42,600	1.72	24	35	25	50	67	70
15 kW 12 lbs.	ECB29-15CB (28K38) (1) 30A & (1) 60A Circuit Breaker ECB29EH-15CB (91K69) (1) 30A & (1) 60A Circuit Breaker	2	208	11.3	38,400	1.72	24	37	⁴ 25	⁴ 50	71	80
			220	12.6	43,000	1.72	28	42	30	60	72	80
			230	13.8	47,000	1.72	28	42	30	60	72	80
			240	15.0	51,200	1.72	28	42	30	60	80	80
20 kW 19 lbs.	ECB29-20CB (11L31) (1) 50A & (1) 60A Circuit Breaker ECB29EH-20CB (91K70) (1) 50A & (1) 60A Circuit Breaker	2	208	15.0	51,200	1.72	44	41	⁴ 45	60	95	100
			220	16.8	57,300	1.72	49	46	50	60	97	100
			230	18.4	62,700	1.72	49	46	50	60	97	100
			240	20.0	68,200	1.72	49	46	50	60	106	110
THREE PHASE												
8 kW 5 lbs.	ECB29-8 (28K42) Terminal Block	1	208	6.0	20,500	1.72	23	---	25	---	---	---
			220	6.7	22,900	1.72	26	---	30	---	---	---
			230	7.3	25,100	1.72	26	---	30	---	---	---
			240	8.0	27,300	1.72	26	---	30	---	---	---
10 kW 6 lbs.	ECB29-10 (28K43) Terminal Block	1	208	7.5	25,600	1.72	28	---	30	---	---	---
			220	8.4	28,700	1.72	32	---	35	---	---	---
			230	9.2	31,400	1.72	32	---	35	---	---	---
			240	10.0	34,100	1.72	32	---	35	---	---	---
15 kW 12 lbs.	ECB29-10 (28K47) (3) 20A Fuses	1	440	8.4	28,700	1.1	16	---	20	---	---	---
			460	9.2	31,400	1.1	16	---	20	---	---	---
			480	10.0	34,100	1.1	16	---	20	---	---	---
			208	11.3	38,400	1.72	41	---	⁴ 45	---	---	---
20 kW 19 lbs.	ECB29-15CB (28K44) (1) 50A Circuit breaker	1	220	12.6	43,000	1.72	47	---	50	---	---	---
			230	13.5	47,000	1.72	47	---	50	---	---	---
			240	15.0	51,200	1.72	47	---	50	---	---	---
			440	12.6	43,000	1.1	24	---	30	---	---	---
20 kW 19 lbs.	ECB29-15 (28K48) (3) 25A Fuses	1	460	13.8	47,000	1.1	24	---	30	---	---	---
			480	15.0	51,200	1.1	24	---	30	---	---	---
			208	15.0	51,200	1.72	28	21	⁴ 30	⁴ 30	56	60
			220	16.8	57,300	1.72	32	24	35	35	58	60
20 kW 19 lbs.	ECB29-20CB (28K45) (2) 35A Circuit breaker	2	230	18.4	62,700	1.72	32	24	35	35	58	60
			240	20.0	68,200	1.72	32	24	35	35	62	70

NOTE - Circuit 1 Minimum Circuit Ampacity includes the Blower Motor Full Load Amps.

¹ Electric heater capacity only - does not include additional blower motor heat capacity.

² Amps shown are for blower motor only.

³ Refer to National or Canadian Electrical Code manual to determine wire, fuse and disconnect size requirements. Use wires suitable for at least 167°F (75°C).

⁴ Bold text indicates that the circuit breaker on CB" circuit breaker models must be replaced with size noted. See Table on Page 5.

⁵ HACR type circuit breaker or fuse.

ELECTRIC HEAT DATA - CBX32M-042

Model Number	No. of Stages	Input			² Blower Motor Full Load Amps	³ Minimum Circuit Ampacity		⁵ Maximum Overcurrent Protection		Single Point Power Source		
		Volts	kW	¹ Btuh		Ckt 1	Ckt 2	Ckt 1	Ckt 2	³ Minimum Circuit Ampacity	⁵ Maximum Overcurrent Protection	
SINGLE PHASE												
4 kW 4 lbs.	ECB29-4 (55W87) Terminal Block ECB29-4CB (55W88) 30A Circuit breaker	1	208	3.0	10,250	2.4	21	---	⁴ 25	---	---	---
			220	3.4	11,450	2.4	24	---	⁴ 25	---	---	---
			230	3.7	12,550	2.4	24	---	⁴ 25	---	---	---
			240	4.0	13,650	2.4	24	---	⁴ 25	---	---	---
5 kW 4 lbs.	ECB29-5 (28K31) Terminal Block ECB29-5CB (28K32) 30A Circuit breaker	1	208	3.8	12,800	2.4	26	---	30	---	---	---
			220	4.2	14,300	2.4	29	---	30	---	---	---
			230	4.6	15,700	2.4	29	---	30	---	---	---
6 kW 4 lbs.	ECB29-6 (47L22) Terminal Block ECB29-6CB (47L23) 35A Circuit breaker	1	208	4.5	15,400	2.4	30	---	⁴ 30	---	---	---
			220	5.0	17,100	2.4	34	---	35	---	---	---
			230	5.5	18,800	2.4	34	---	35	---	---	---
			240	6.0	20,500	2.4	34	---	35	---	---	---
8 kW 5 lbs.	ECB29-8 (28K33) Terminal Block ECB29-8CB (28K34) 45A Circuit breaker	1	208	6.0	20,500	2.4	40	---	⁴ 40	---	---	---
			220	6.7	22,900	2.4	45	---	45	---	---	---
			230	7.3	25,100	2.4	45	---	45	---	---	---
			240	8.0	27,300	2.4	45	---	45	---	---	---
9 kW 5 lbs.	ECB29-9CB (10L11) 60A Circuit breaker ECB29EH-9CB (91K67) 60A Circuit breaker	2	208	6.8	23,100	2.4	44	---	⁴ 45	---	---	---
			220	7.6	25,800	2.4	50	---	⁴ 50	---	---	---
			230	8.3	28,200	2.4	50	---	⁴ 50	---	---	---
			240	9.0	30,700	2.4	50	---	⁴ 50	---	---	---
10 kW 6 lbs.	ECB29-10 (28K35) Terminal Block ECB29-10CB (28K36) 60A Circuit breaker	2	208	7.5	25,600	2.4	48	---	⁴ 50	---	---	---
			220	8.4	28,700	2.4	55	---	60	---	---	---
			230	9.2	31,400	2.4	55	---	60	---	---	---
			240	10.0	34,100	2.4	55	---	60	---	---	---
12.5 kW 10 lbs.	ECB29-12.5CB (28K37) (1) 25A & (1) 50A Circuit breaker ECB29EH-12.5CB (91K68) (1) 25A & (1) 50A Circuit breaker	2	208	9.4	32,000	2.4	22	31	25	⁴ 45	61	70
			220	10.5	35,800	2.4	25	35	25	50	63	70
			230	11.5	39,200	2.4	25	35	25	50	63	70
			240	12.5	42,600	2.4	25	35	25	50	68	70
15 kW 12 lbs.	ECB29-15CB (28K38) (1) 30A & (1) 60A Circuit Breaker ECB29EH-15CB (91K69) (1) 30A & (1) 60A Circuit Breaker	2	208	11.3	38,400	2.4	26	37	30	⁴ 50	72	80
			220	12.6	43,000	2.4	29	42	30	60	74	80
			230	13.8	47,000	2.4	29	42	30	60	74	80
			240	15.0	51,200	2.4	29	42	30	60	81	90
20 kW 19 lbs.	ECB29-20CB (11L31) (1) 50A & (1) 60A Circuit Breaker ECB29EH-20CB (91K70) (1) 50A & (1) 60A Circuit Breaker	2	208	15.0	51,200	2.4	45	41	⁴ 45	60	95	100
			220	16.8	57,300	2.4	50	46	50	60	99	100
			230	18.4	62,700	2.4	50	46	50	60	99	100
			240	20.0	68,200	2.4	50	46	50	60	107	110
THREE PHASE												
8 kW 5 lbs.	ECB29-8 (28K42) Terminal Block	1	208	6.0	20,500	2.4	24	---	25	---	---	---
			220	6.7	22,900	2.4	27	---	30	---	---	---
			230	7.3	25,100	2.4	27	---	30	---	---	---
			240	8.0	27,300	2.4	27	---	30	---	---	---
10 kW 6 lbs.	ECB29-10 (28K43) Terminal Block	1	208	7.5	25,600	2.4	29	---	30	---	---	---
			220	8.4	28,700	2.4	33	---	35	---	---	---
			230	9.2	31,400	2.4	33	---	35	---	---	---
			240	10.0	34,100	2.4	33	---	35	---	---	---
15 kW 12 lbs.	ECB29-15CB (28K44) (1) 50A Circuit breaker	1	208	11.3	38,400	2.4	42	---	⁴ 45	---	---	---
			220	12.6	43,000	2.4	48	---	50	---	---	---
			230	13.5	47,000	2.4	48	---	50	---	---	---
			240	15.0	51,200	2.4	48	---	50	---	---	---
20 kW 19 lbs.	ECB29-20CB (28K45) (2) 35A Circuit breaker	2	208	15.0	51,200	2.4	29	21	⁴ 30	⁴ 30	56	60
			220	16.8	57,300	2.4	33	24	35	35	60	60
			230	18.4	62,700	2.4	33	24	35	35	60	60
			240	20.0	68,200	2.4	33	24	35	35	63	70

NOTE - Circuit 1 Minimum Circuit Ampacity includes the Blower Motor Full Load Amps.

¹ Electric heater capacity only - does not include additional blower motor heat capacity.

² Amps shown are for blower motor only.

³ Refer to National or Canadian Electrical Code manual to determine wire, fuse and disconnect size requirements. Use wires suitable for at least 167°F (75°C).

⁴ Bold text indicates that the circuit breaker on CB[®] circuit breaker models must be replaced with size noted. See Table on Page 5.

⁵ HACR type circuit breaker or fuse.

ELECTRIC HEAT DATA - CBX32M-048

Model Number	No. of Stages	Volts Input	kW Input	1 Btuh Input	2 Blower Motor Full Load Amps	3 Minimum Circuit Ampacity			5 Maximum Overcurrent Protection			Single Point Power Source		
						Ckt 1	Ckt 2	Ckt 3	Ckt 1	Ckt 2	Ckt 3	3 Minimum Circuit Ampacity	5 Maximum Overcurrent Protection	
SINGLE PHASE														
4 kW 4 lbs. ECB29-4 (55W87) Terminal Block ECB29-4CB (55W88) 30A Circuit breaker	1	208	3.0	10,250	2.4	21	---	---	---	4 25	---	---	---	---
		220	3.4	11,450	2.4	24	---	---	---	4 25	---	---	---	---
		230	3.7	12,550	2.4	24	---	---	---	4 25	---	---	---	---
		240	4.0	13,650	2.4	24	---	---	---	4 25	---	---	---	---
5 kW 4 lbs. ECB29-5 (28K31) Terminal Block ECB29-5CB (28K32) 30A Circuit breaker	1	208	3.8	12,800	2.4	26	---	---	30	---	---	---	---	---
		220	4.2	14,300	2.4	29	---	---	30	---	---	---	---	---
		230	4.6	15,700	2.4	29	---	---	30	---	---	---	---	---
		240	5.0	17,100	2.4	29	---	---	30	---	---	---	---	---
6 kW 4 lbs. ECB29-6 (47L22) Terminal Block ECB29-6CB (47L23) 35A Circuit breaker	1	208	4.5	15,400	2.4	30	---	---	4 30	---	---	---	---	---
		220	5.0	17,100	2.4	34	---	---	35	---	---	---	---	---
		230	5.5	18,800	2.4	34	---	---	35	---	---	---	---	---
		240	6.0	20,500	2.4	34	---	---	35	---	---	---	---	---
8 kW 5 lbs. ECB29-8 (28K33) Terminal Block ECB29-8CB (28K34) 45A Circuit breaker	1	208	6.0	20,500	2.4	40	---	---	4 40	---	---	---	---	---
		220	6.7	22,900	2.4	45	---	---	45	---	---	---	---	---
		230	7.3	25,100	2.4	45	---	---	45	---	---	---	---	---
		240	8.0	27,300	2.4	45	---	---	45	---	---	---	---	---
9 kW 5 lbs. ECB29-9CB (10L11) 60A Circuit breaker ECB29EH-9CB (91K67) 60A Circuit breaker	2	208	6.8	23,100	2.4	44	---	---	4 45	---	---	---	---	---
		220	7.6	25,800	2.4	50	---	---	4 50	---	---	---	---	---
		230	8.3	28,200	2.4	50	---	---	4 50	---	---	---	---	---
		240	9.0	30,700	2.4	50	---	---	4 50	---	---	---	---	---
10 kW 6 lbs. ECB29-10 (28K35) Terminal Block ECB29-10CB (28K36) 60A Circuit breaker	2	208	7.5	25,600	2.4	48	---	---	4 50	---	---	---	---	---
		220	8.4	28,700	2.4	55	---	---	60	---	---	---	---	---
		230	9.2	31,400	2.4	55	---	---	60	---	---	---	---	---
		240	10.0	34,100	2.4	55	---	---	60	---	---	---	---	---
12.5 kW 10 lbs. ECB29-12.5CB (28K37) ECB29EH-12.5CB (91K68) (1) 25A and (1) 50A Circuit breaker	2	208	9.4	32,000	2.4	22	31	---	25	4 45	---	61	70	---
		220	10.5	35,800	2.4	25	35	---	25	50	---	63	70	---
		230	11.5	39,200	2.4	25	35	---	25	50	---	63	70	---
		240	12.5	42,600	2.4	25	35	---	25	50	---	68	70	---
15 kW 12 lbs. ECB29-15CB (28K38) ECB29EH-15CB (91K69) (1) 30A and (1) 60A Circuit breaker	2	208	11.3	38,400	2.4	26	37	---	30	4 50	---	72	80	---
		220	12.6	43,000	2.4	29	42	---	30	60	---	74	80	---
		230	13.5	47,000	2.4	29	42	---	30	60	---	74	80	---
		240	15.0	51,200	2.4	29	42	---	30	60	---	81	90	---
20 kW 19 lbs. ECB29-20CB (11L31) ECB29EH-20CB (91K70) (1) 50A and (1) 60A Circuit breaker	2	208	15.0	51,200	2.4	45	41	---	4 45	60	---	95	100	---
		220	16.8	57,300	2.4	50	46	---	50	60	---	99	100	---
		230	18.4	62,700	2.4	50	46	---	50	60	---	99	100	---
		240	20.0	68,200	2.4	50	46	---	50	60	---	107	110	---
25 kW 19 lbs. ECB29-25CB (28K40) (3) 50A Circuit breakers	3	208	18.8	64,100	2.4	40	31	31	4 40	4 45	4 45	118	125	---
		220	21.0	71,700	2.4	47	35	35	50	50	50	120	125	---
		230	23.0	78,300	2.4	47	35	35	50	50	50	120	125	---
		240	25.0	85,300	2.4	47	35	35	50	50	50	133	150	---

NOTE - Circuit 1 Minimum Circuit Ampacity includes the Blower Motor Full Load Amps.

¹ Electric heater capacity only - does not include additional blower motor heat capacity.

² Amps shown are for blower motor only.

³ Refer to National or Canadian Electrical Code manual to determine wire, fuse and disconnect size requirements. Use wires suitable for at least 167°F (75°C).

⁴ Bold text indicates that the circuit breaker on CB" circuit breaker models must be replaced with size noted. See Table on Page 5.

⁵ HACR type circuit breaker or fuse.

ELECTRIC HEAT DATA - CBX32M-048

Model Number	No. of Stages	Input			² Blower Motor Full Load Amps	³ Minimum Circuit Ampacity		⁷ Maximum Overcurrent Protection		Single Point Power Source		
		Volts	kW	¹ Btuh		Ckt 1	Ckt 2	Ckt 1	Ckt 2	³ Minimum Circuit Ampacity	⁵ Maximum Overcurrent Protection	
THREE PHASE												
8 kW 5 lbs.	ECB29-8 (28K42) Terminal block	1	208	6.0	20,500	2.4	24	---	25	---	---	---
			220	6.7	22,900	2.4	27	---	30	---	---	---
			230	7.3	25,100	2.4	27	---	30	---	---	---
			240	8.0	27,300	2.4	27	---	30	---	---	---
10 kW 6 lbs.	ECB29-10 (28K43) Terminal Block	1	208	7.5	25,600	2.4	29	---	30	---	---	---
			220	8.4	28,700	2.4	33	---	35	---	---	---
			230	9.2	31,400	2.4	33	---	35	---	---	---
			240	10.0	34,100	2.4	33	---	35	---	---	---
	ECB29-10 (28K47) (3) 20A Fuses	1	440	8.4	28,700	1.3	17	---	20	---	---	---
			460	9.2	31,400	1.3	17	---	20	---	---	---
			480	10.0	34,100	1.3	17	---	20	---	---	---
	15 kW 12 lbs.	ECB29-15CB (28K44) 50A Circuit breaker	1	208	11.3	38,400	2.4	42	---	⁴ 45	---	---
220				12.6	43,000	2.4	48	---	50	---	---	---
230				13.5	47,000	2.4	48	---	50	---	---	---
240				15.0	51,200	2.4	48	---	50	---	---	---
ECB29-15 (28K48) (3) 25A Fuses		1	440	12.6	43,000	1.3	24	---	30	---	---	---
			460	13.8	47,000	1.3	24	---	30	---	---	---
			480	15.0	51,200	1.3	24	---	30	---	---	---
20 kW 19 lbs.	ECB29-20CB (28K45) (2) 35A Circuit breaker	2	208	15.0	51,200	2.4	29	21	⁴ 30	⁴ 30	56	60
			220	16.8	57,300	2.4	33	24	35	35	60	60
			230	18.4	62,700	2.4	33	24	35	35	60	60
			240	20.0	68,200	2.4	33	24	35	35	63	70
	ECB29-20 (28K49) (3) 35A Fuses	1	440	16.8	57,300	1.3	32	---	35	---	---	---
			460	18.4	62,700	1.3	32	---	35	---	---	---
			480	20.0	68,200	1.3	32	---	35	---	---	---
	⁵ ECB29-20 (28K51) (3) 25A Fuses	1	550	16.8	57,300	⁶ 1.3	26	---	30	---	---	---
			575	18.4	62,700	⁶ 1.3	26	---	30	---	---	---
			600	20.0	68,200	⁶ 1.3	26	---	30	---	---	---
25 kW 19 lbs.	ECB29-25CB (28K46) (2) 45A Circuit breaker	2	208	18.8	64,100	2.4	35	27	⁴ 40	⁴ 40	70	70
			220	21.0	71,700	2.4	41	30	45	45	74	80
			230	23.0	78,300	2.4	41	30	45	45	74	80
			240	25.0	85,300	2.4	41	30	45	45	78	80
	ECB29-25 (28K50) (3) 40A Fuses	2	440	21.0	71,700	1.3	39	---	45	---	---	---
			460	23.0	78,300	1.3	39	---	45	---	---	---
			480	25.0	85,300	1.3	39	---	45	---	---	---
	⁵ ECB29-25 (28K52) (3) 35A Fuses	2	550	21.0	71,700	⁶ 1.3	32	---	35	---	---	---
			575	23.0	78,300	⁶ 1.3	32	---	35	---	---	---
			600	25.0	85,300	⁶ 1.3	32	---	35	---	---	---

NOTE – Circuit 1 Minimum Circuit Ampacity includes the Blower Motor Full Load Amps.

¹ Electric heater capacity only - does not include additional blower motor heat capacity.

² Amps shown are for blower motor only.

³ Refer to National or Canadian Electrical Code manual to determine wire, fuse and disconnect size requirements. Use wires suitable for at least 167°F (75°C).

⁴ Bold text indicates that the circuit breaker on "CB" circuit breaker models must be replaced with size noted. See Table on Page 6.

⁵ All 575v electric heaters are used with 460V air handler units. A 575V to 460V Step-down transformer for the air handler unit is furnished with all 575V electric heaters.

⁶ Blower motor is rated at 460V.

⁷ HACR type circuit breaker or fuse.

ELECTRIC HEAT DATA - CBX32M-060

Model Number	No. of Stages	Volts Input	kW Input	1 Btuh Input	2 Blower Motor Full Load Amps	3 Minimum Circuit Ampacity			5 Maximum Overcurrent Protection			Single Point Power Source		
						Ckt 1	Ckt 2	Ckt 3	Ckt 1	Ckt 2	Ckt 3	3 Minimum Circuit Ampacity	5 Maximum Overcurrent Protection	
SINGLE PHASE														
4 kW 4 lbs.	ECB29-4 (55W87) Terminal Block ECB29-4CB (55W88) 30A Circuit breaker	1	208	3.0	10,250	3.9	23	---	---	4 25	---	---	---	---
			220	3.4	11,450	3.9	26	---	---	30	---	---	---	---
			230	3.7	12,550	3.9	26	---	---	30	---	---	---	---
			240	4.0	13,650	3.9	26	---	---	30	---	---	---	---
5 kW 4 lbs.	ECB29-5 (28K31) Terminal Block ECB29-5CB (28K32) 30A Circuit breaker	1	208	3.8	12,800	3.9	27	---	---	30	---	---	---	---
			220	4.2	14,300	3.9	31	---	---	4 35	---	---	---	---
			230	4.6	15,700	3.9	31	---	---	4 35	---	---	---	---
			240	5.0	17,100	3.9	31	---	---	4 35	---	---	---	---
6 kW 4 lbs.	ECB29-6 (47L22) Terminal Block ECB29-6CB (47L23) 35A Circuit breaker	1	208	4.5	15,400	3.9	31	---	---	35	---	---	---	---
			220	5.0	17,100	3.9	36	---	---	4 40	---	---	---	---
			230	5.5	18,800	3.9	36	---	---	4 40	---	---	---	---
			240	6.0	20,500	3.9	36	---	---	4 40	---	---	---	---
8 kW 5 lbs.	ECB29-8 (28K33) Terminal Block ECB29-8CB (28K34) 45A Circuit breaker	1	208	6.0	20,500	3.9	40	---	---	4 40	---	---	---	---
			220	6.7	22,900	3.9	47	---	---	4 50	---	---	---	---
			230	7.3	25,100	3.9	47	---	---	4 50	---	---	---	---
			240	8.0	27,300	3.9	47	---	---	4 50	---	---	---	---
9 kW 5 lbs.	ECB29-9CB (10L11) 60A Circuit breaker ECB29EH-9CB (91K67) 60A Circuit breaker	2	208	6.8	23,100	3.9	45	---	---	4 45	---	---	---	---
			220	7.6	25,800	3.9	52	---	---	60	---	---	---	---
			230	8.3	28,200	3.9	52	---	---	60	---	---	---	---
			240	9.0	30,700	3.9	52	---	---	60	---	---	---	---
10 kW 6 lbs.	ECB29-10 (28K35) Terminal Block ECB29-10CB (28K36) 60A Circuit breaker	2	208	7.5	25,600	3.9	51	---	---	60	---	---	---	---
			220	8.4	28,700	3.9	57	---	---	60	---	---	---	---
			230	9.2	31,400	3.9	57	---	---	60	---	---	---	---
			240	10.0	34,100	3.9	57	---	---	60	---	---	---	---
12.5 kW 10 lbs.	ECB29-12.5CB (28K37) ECB29EH-12.5CB (91K68) (1) 25A and (1) 50A Circuit breaker	2	208	9.4	32,000	3.9	23	31	---	25	4 45	---	63	70
			220	10.5	35,800	3.9	27	35	---	4 30	50	---	66	70
			230	11.5	39,200	3.9	27	35	---	4 30	50	---	66	70
			240	12.5	42,600	3.9	27	35	---	4 30	50	---	70	70
15 kW 12 lbs.	ECB29-15CB (28K38) ECB29EH-15CB (91K69) (1) 30A and (1) 60A Circuit breaker	2	208	11.3	38,400	3.9	27	37	---	30	4 50	---	74	80
			220	12.6	43,000	3.9	31	42	---	4 35	60	---	77	80
			230	13.5	47,000	3.9	31	42	---	4 35	60	---	77	80
			240	15.0	51,200	3.9	31	42	---	4 35	60	---	83	90
20 kW 19 lbs.	ECB29-20CB (11L31) ECB29EH-20CB (91K70) (1) 50A and (1) 60A Circuit breaker	2	208	15.0	51,200	3.9	46	41	---	50	60	---	97	100
			220	16.8	57,300	3.9	52	46	---	4 60	60	---	102	110
			230	18.4	62,700	3.9	52	46	---	4 60	60	---	102	110
			240	20.0	68,200	3.9	52	46	---	4 60	60	---	109	110
25 kW 19 lbs.	ECB29-25CB (28K40) (3) 50A Circuit breakers	3	208	18.8	64,100	3.9	42	31	31	4 45	4 45	4 45	120	125
			220	21.0	71,700	3.9	48	35	35	50	50	50	122	125
			230	23.0	78,300	3.9	48	35	35	50	50	50	122	125
			240	25.0	85,300	3.9	48	35	35	50	50	50	135	150
30 kW 19 lbs.	ECB29-30CB (28K41) (3) 60A Circuit breakers	3	208	22.5	76,900	3.9	51	37	37	60	4 50	4 50	144	150
			220	25.2	86,000	3.9	56	42	42	60	60	60	144	150
			230	27.5	94,000	3.9	56	42	42	60	60	60	144	150
			240	30.0	102,400	3.9	56	42	42	60	60	60	161	175

NOTE - Circuit 1 Minimum Circuit Ampacity includes the Blower Motor Full Load Amps.

1 Electric heater capacity only - does not include additional blower motor heat capacity.

2 Amps shown are for blower motor only.

3 Refer to National or Canadian Electrical Code manual to determine wire, fuse and disconnect size requirements. Use wires suitable for at least 167°F.

4 Bold text indicates that the circuit breaker on "CB" circuit breaker models must be replaced with size noted. See Table on Page 6.

5 HACR type circuit breaker or fuse.

ELECTRIC HEAT DATA - CBX32M-060

Model Number	No. of Stages	Input			² Blower Motor Full Load Amps	³ Minimum Circuit Ampacity		⁷ Maximum Overcurrent Protection		Single Point Power Source			
		Volts	kW	¹ Btuh		Ckt 1	Ckt 2	Ckt 1	Ckt 2	³ Minimum Circuit Ampacity	⁵ Maximum Overcurrent Protection		
THREE PHASE													
8 kW 5 lbs.	ECB29-8 (28K42) Terminal block	1	208	6.0	20,500	3.9	25	---	25	---	---	---	
			220	6.7	22,900	3.9	29	---	30	---	---	---	
			230	7.3	25,100	3.9	29	---	30	---	---	---	
			240	8.0	27,300	3.9	29	---	30	---	---	---	
10 kW 6 lbs.	ECB29-10 (28K43) Terminal Block	1	208	7.5	25,600	3.9	30	---	30	---	---	---	
			220	8.4	28,700	3.9	35	---	35	---	---	---	
			230	9.2	31,400	3.9	35	---	35	---	---	---	
			240	10.0	34,100	3.9	35	---	35	---	---	---	
	ECB29-10 (28K47) (3) 20A Fuses	1	1	440	8.4	28,700	1.9	17	---	20	---	---	---
				460	9.2	31,400	1.9	17	---	20	---	---	---
				480	10.0	34,100	1.9	17	---	20	---	---	---
				440	8.4	28,700	1.9	17	---	20	---	---	---
15 kW 12 lbs.	ECB29-15CB (28K44) 50A Circuit breaker	1	208	11.3	38,400	3.9	43	---	4 45	---	---	---	
			220	12.6	43,000	3.9	50	---	50	---	---	---	
			230	13.5	47,000	3.9	50	---	50	---	---	---	
			240	15.0	51,200	3.9	50	---	50	---	---	---	
	ECB29-15 (28K48) (3) 25A Fuses	1	1	440	12.6	43,000	1.9	25	---	25	---	---	---
				460	13.8	47,000	1.9	25	---	25	---	---	---
				480	15.0	51,200	1.9	25	---	25	---	---	---
				440	12.6	43,000	1.9	25	---	25	---	---	---
20 kW 19 lbs.	ECB29-20CB (28K45) (2) 35A Circuit breaker	2	208	15.0	51,200	3.9	30	21	4 30	4 30	58	60	
			220	16.8	57,300	3.9	35	24	35	35	63	70	
			230	18.4	62,700	3.9	35	24	35	35	63	70	
			240	20.0	68,200	3.9	35	24	35	35	65	70	
	ECB29-20 (28K49) (3) 35A Fuses	1	1	440	16.8	57,300	1.9	32	---	35	---	---	---
				460	18.4	62,700	1.9	32	---	35	---	---	---
				480	20.0	68,200	1.9	32	---	35	---	---	---
	⁵ ECB29-20 (28K51) (3) 25A Fuses	1	1	550	16.8	57,300	⁶ 1.9	26	---	30	---	---	---
				575	18.4	62,700	⁶ 1.9	26	---	30	---	---	---
				600	20.0	68,200	⁶ 1.9	26	---	30	---	---	---
25 kW 19 lbs.	ECB29-25CB (28K46) (2) 45A Circuit breaker	2	208	18.8	64,100	3.9	37	27	4 40	4 40	72	80	
			220	21.0	71,700	3.9	43	30	45	45	77	80	
			230	23.0	78,300	3.9	43	30	45	45	77	80	
			240	25.0	85,300	3.9	43	30	45	45	80	80	
	ECB29-25 (28K50) (3) 40A Fuses	2	2	440	21.0	71,700	1.9	40	---	45	---	---	---
				460	23.0	78,300	1.9	40	---	45	---	---	---
				480	25.0	85,300	1.9	40	---	45	---	---	---
	⁵ ECB29-25 (28K52) (3) 35A Fuses	2	2	550	21.0	71,700	⁶ 1.9	32	---	35	---	---	---
				575	23.0	78,300	⁶ 1.9	32	---	35	---	---	---
				600	25.0	85,300	⁶ 1.9	32	---	35	---	---	---

NOTE – Circuit 1 Minimum Circuit Ampacity includes the Blower Motor Full Load Amps.

¹ Electric heater capacity only - does not include additional blower motor heat capacity.

² Amps shown are for blower motor only.

³ Refer to National or Canadian Electrical Code manual to determine wire, fuse and disconnect size requirements. Use wires suitable for at least 167°F (75°C).

⁴ Bold text indicates that the circuit breaker on "CB" circuit breaker models must be replaced with size noted. See Table on Page 6.

⁵ All 575v electric heaters are used with 460V air handler units. A 575V to 460V Step-down transformer for the air handler unit is furnished with all 575V electric heaters.

⁶ Blower motor is rated at 460V.

⁷ HACR type circuit breaker or fuse.

DIMENSIONS - INCHES (MM)

UPFLOW POSITION

DETAIL OF PIPING PLATE

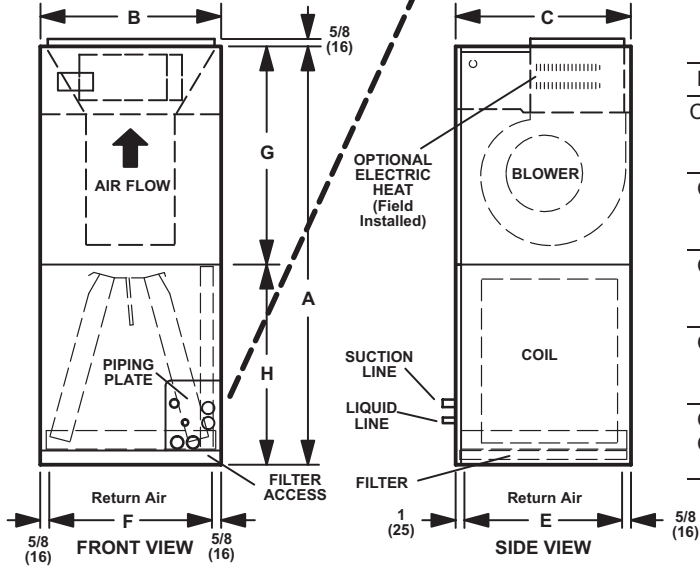
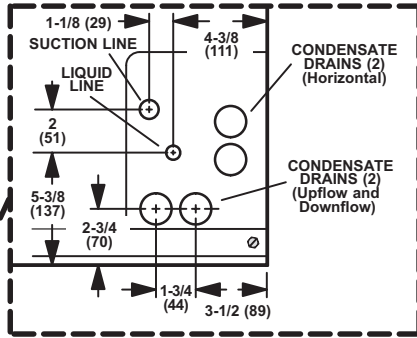
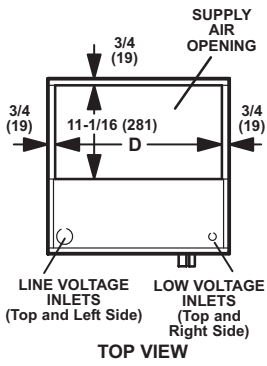

Model No.	A	B	C	D	E	F	G	H
CBX32M-018/024	in. 45-1/4	16-1/4	20-5/8	14-3/4	19	15	24-5/8	20-5/8
	mm 1149	413	524	375	483	381	625	524
CBX32M-030	in. 49-1/4	21-1/4	20-5/8	19-3/4	19	20	24-5/8	24-5/8
	mm 1251	540	524	502	483	508	625	625
CBX32M-036	in. 51	21-1/4	22-5/8	19-3/4	21	20	26-3/8	24-5/8
	mm 1295	540	575	502	533	508	670	625
CBX32M-042	in. 52-1/2	21-1/4	22-5/8	19-3/4	21	20	27-7/8	24-5/8
	mm 1334	540	575	502	533	508	708	625
CBX32M-048	in. 58-1/2	21-1/4	24-5/8	19-3/4	23	20	27-7/8	30-5/8
CBX32M-060	mm 1486	540	625	502	584	508	708	778

DOWNFLOW POSITION

DETAIL OF PIPING PLATE

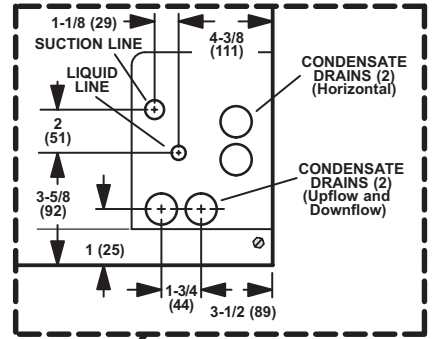
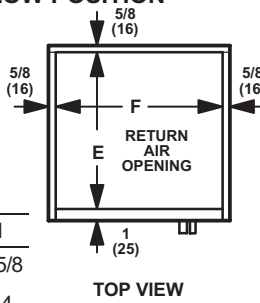

Model No.	A	B	C	D	E	F	G	H
CBX32M-018/024	in. 45-1/4	16-1/4	20-5/8	14-3/4	19	15	24-5/8	20-5/8
	mm 1149	413	524	375	483	381	625	524
CBX32M-030	in. 49-1/4	21-1/4	20-5/8	19-3/4	19	20	24-5/8	24-5/8
	mm 1251	540	524	502	483	508	625	625
CBX32M-036	in. 51	21-1/4	22-5/8	19-3/4	21	20	26-3/8	24-5/8
	mm 1295	540	575	502	533	508	670	625
CBX32M-042	in. 52-1/2	21-1/4	22-5/8	19-3/4	21	20	27-7/8	24-5/8
	mm 1334	540	575	502	533	508	708	625
CBX32M-048	in. 58-1/2	21-1/4	24-5/8	19-3/4	23	20	27-7/8	30-5/8
CBX32M-060	mm 1486	540	625	502	584	508	708	778

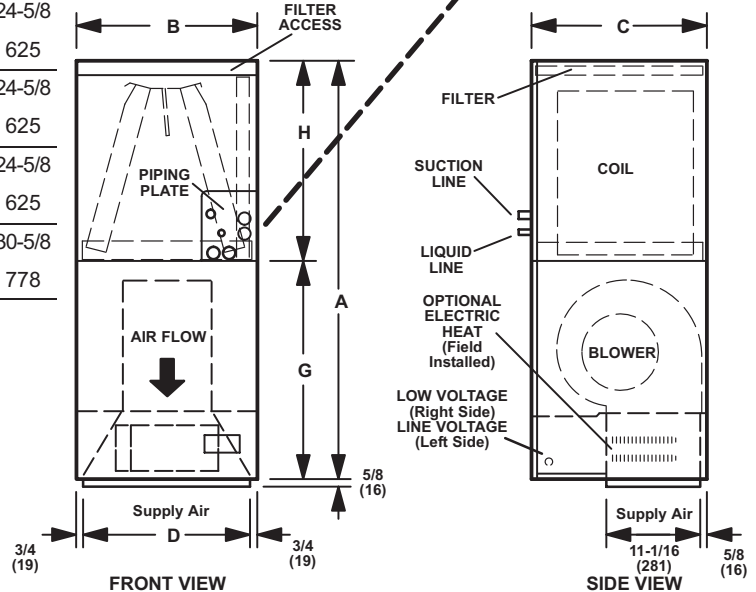

DIMENSIONS - INCHES (MM)

HORIZONTAL POSITION (RIGHT-HAND AIR DISCHARGE)

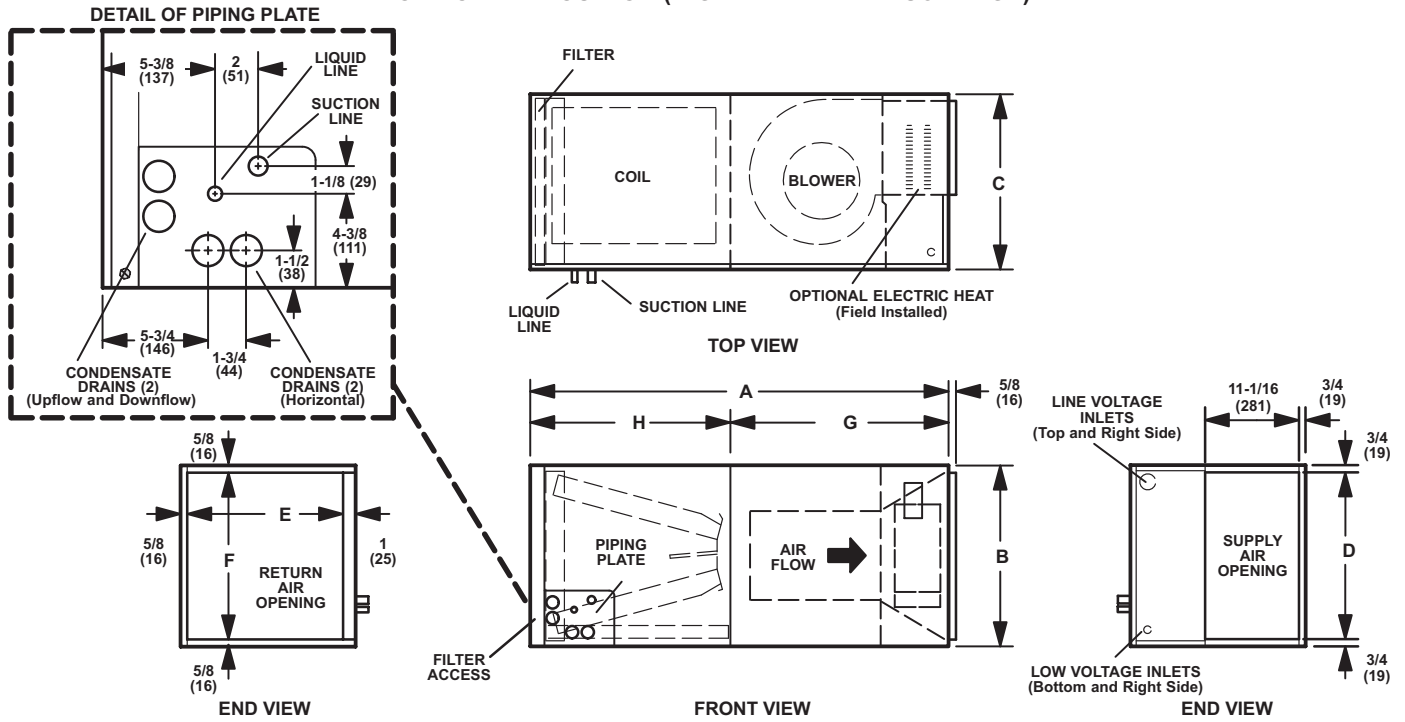

HORIZONTAL POSITION (LEFT-HAND AIR DISCHARGE)

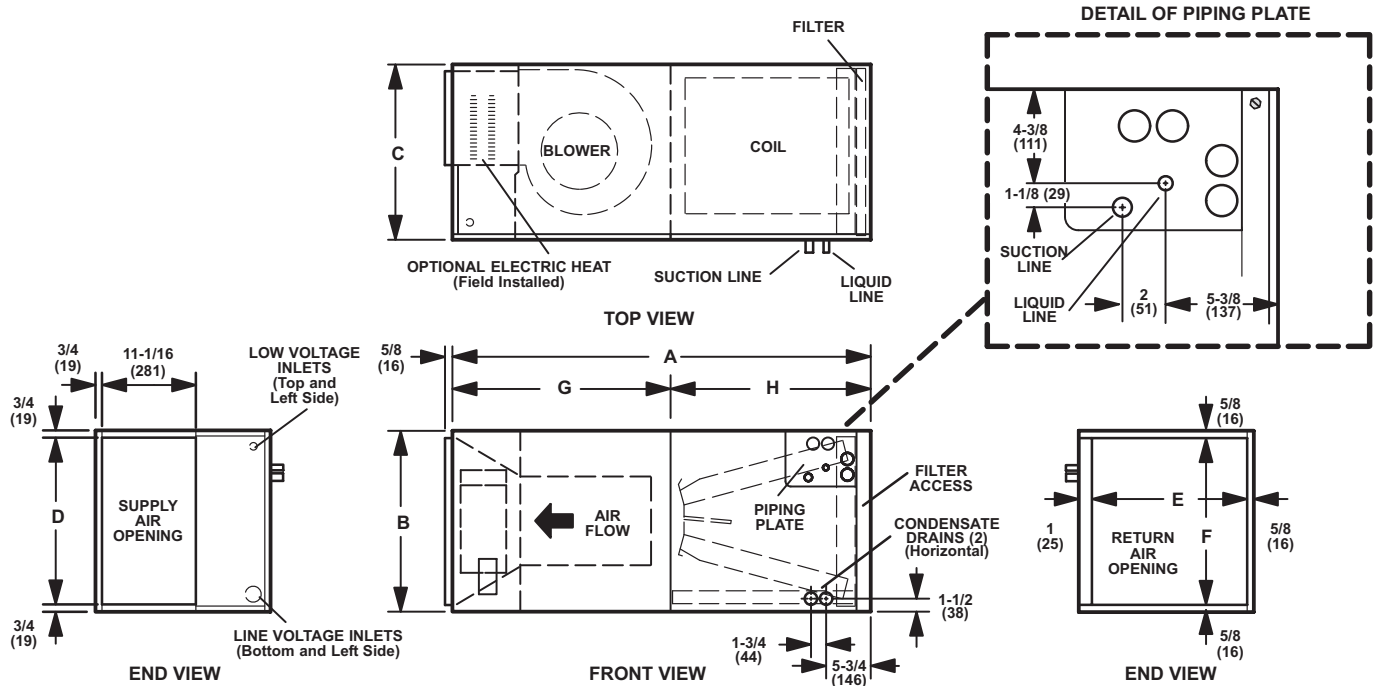

Model No.	A		B		C		D		E		F		G		H	
	inch	mm	inch	mm	inch	mm	inch	mm	inch	mm	inch	mm	inch	mm	inch	mm
CBX32M-018/024	45-1/4	1149	16-1/4	413	20-5/8	524	14-3/4	375	19	483	15	381	24-5/8	625	20-5/8	524
CBX32M-030	49-1/4	1251	21-1/4	540	20-5/8	524	19-3/4	502	19	483	20	508	24-5/8	625	24-5/8	625
CBX32M-036	51	1295	21-1/4	540	22-5/8	575	19-3/4	502	21	533	20	508	26-3/8	670	24-5/8	625
CBX32M-042	52-1/2	1334	21-1/4	540	22-5/8	575	19-3/4	502	21	533	20	508	27-7/8	708	24-5/8	625
CBX32M-048	58-1/2	1486	21-1/4	540	24-5/8	625	19-3/4	502	23	584	20	508	27-7/8	708	30-5/8	778
CBX32M-060																

DIMENSIONS - INCHES (MM)

AIR FLOW

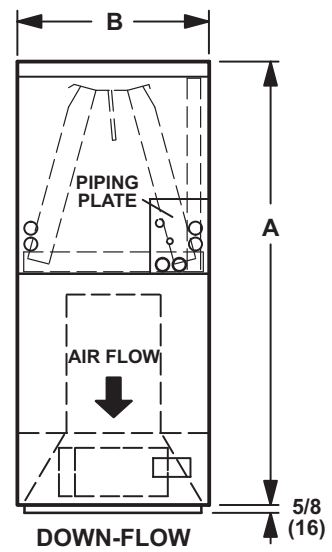
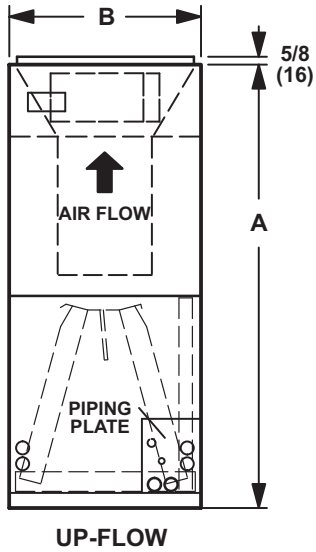
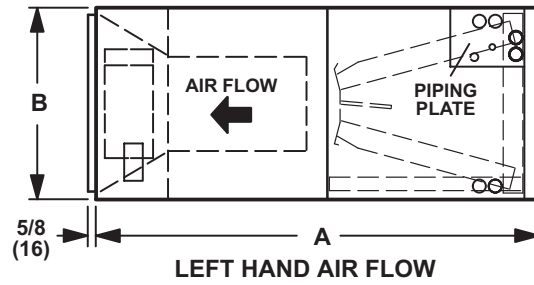
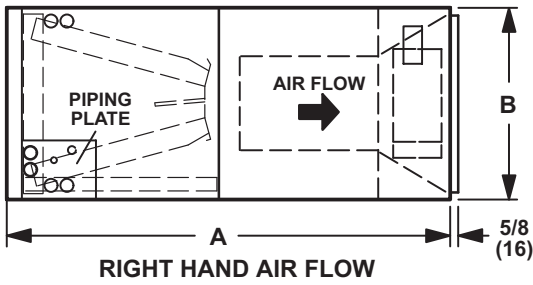

Model No.	A		B	
	in.	mm	in.	mm
CBX32M-018/024	45-1/4	1149	16-1/4	413
CBX32M-030	49-1/4	1251	21-1/4	540
CBX32M-036	51	1295	21-1/4	540
CBX32M-042	52-1/2	1334	21-1/4	540
CBX32M-048 CBX32M-060	58-1/2	1486	21-1/4	540

SIDE RETURN UNIT STAND (Upflow Only)

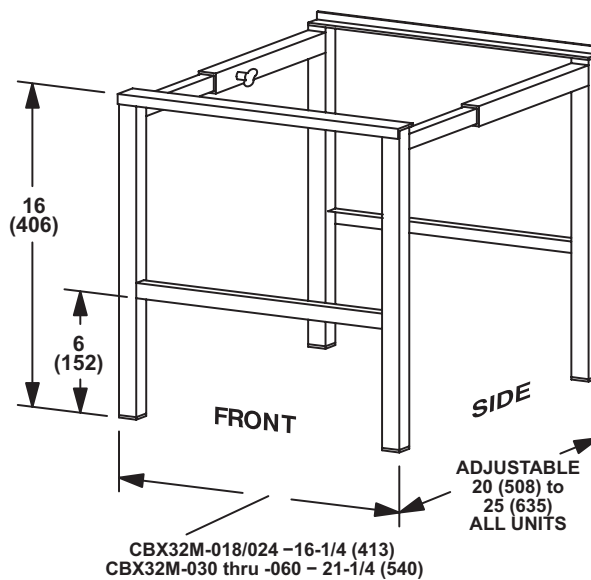

DIMENSIONS - INCHES (MM)

DOWNFLOW COMBUSTIBLE FLOORING BASE

Catalog No. - 34J72

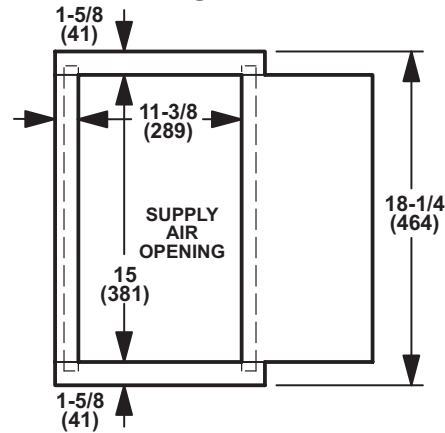
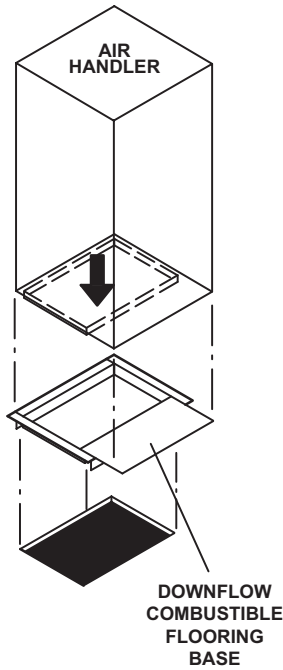

TOP VIEW

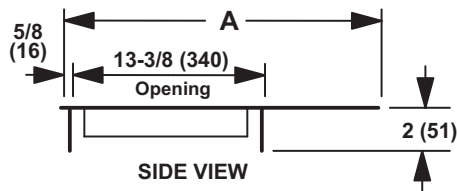

SIDE VIEW

Catalog No. - 44K15

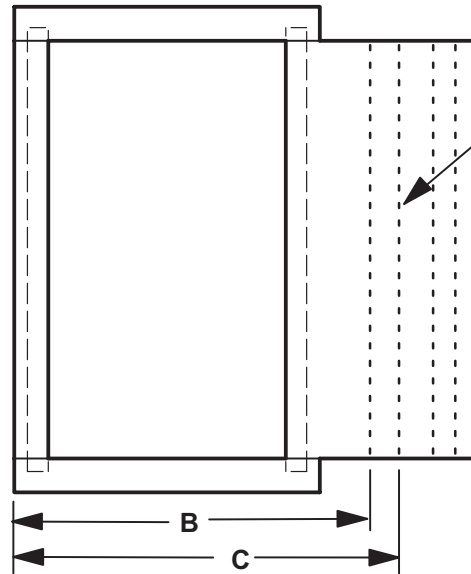
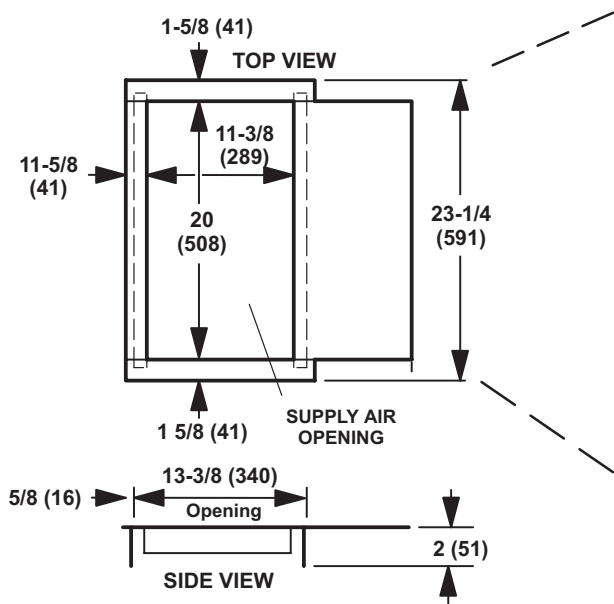

Break Off Extended Width At Pre-perforated Line To Fit Specific Air Handler Being Installed.

Note: Allow For An Additional Two Inch (51 mm) Overhang For Air Handler Positioning Adjustment.

Model No.	-018, -024, -030		-036, -042		-048, -060	
	in.	mm	in.	mm	in.	mm
A	22-1/8	562	---	---	---	---
B	---	---	22-5/8	625	---	---
C	---	---	---	---	24-5/8	625

REVISIONS

Sections	Description of Change
Electric Heat Data	CBX32M-036-042 - Removed 460V models - Not available.



Visit us at www.lennox.com

For the latest technical information, www.lennoxravenet.com

Contact us at 1-800-4-LENNOX

NOTE - Due to Lennox' ongoing commitment to quality, Specifications, Ratings and Dimensions subject to change without notice and without incurring liability. Improper installation, adjustment, alteration, service or maintenance can cause property damage or personal injury. Installation and service must be performed by a qualified installer and servicing agency.

©2014 Lennox Industries, Inc.